



EQUIPMENT

# MICROWAVE OVEN

## Specifications

Cavity Size	: 0.6 cu.ft/ 17L	Interior light	: LED
Power input	: 3000 Watts	Auto programmable	: 100
Power output	: 1800 Watts	Power level	: 11
Power source	: 230-240/50 V/Hz	Magnetrons	: 2
Exterior finish	: Stainless steel	Control type	: Membrane touch
Interior finish	: Stainless steel		
Cavity (W*D*H)	: 330 mm x 310 mm x 175 mm		
Gross (W*D*H)	: 420 mm x 563 mm x 340 mm		
Package (W*D*H)	: 640 mm x 507 mm x 416 mm		
Ship weight (approx.)	: 32 kg		



**PEC18E17-C**

- Large capacity (0.6 cu.ft / 17 L), accommodates a 12" (305 mm) platter.
- Able to withstand the demands of the Commercial Food Service environment with stainless steel cabinet and oven cavity.
- Top and Bottom Energy Feed.
- 11 power levels and 3 cooking stages for different cooking demands.
- 00:60:00 maximum cooking time and 100 auto programs can cover most product demands.
- Time entry option and X2 & X3 multiple quantity pad provide flexible operation.
- USB port for easy and consistent menu customization for multiple (chain) locations.
- Removable Splatter Shield and Stainless Steel Air Intake filter for easy cleaning.
- Oven cavity light to monitor cooking status without opening the door.
- EZ Grab'n Go door handle for reliable use, no moving parts.
- User-friendly touch control pads AND Electronic dial timer with braille navigation.
- Stackable.

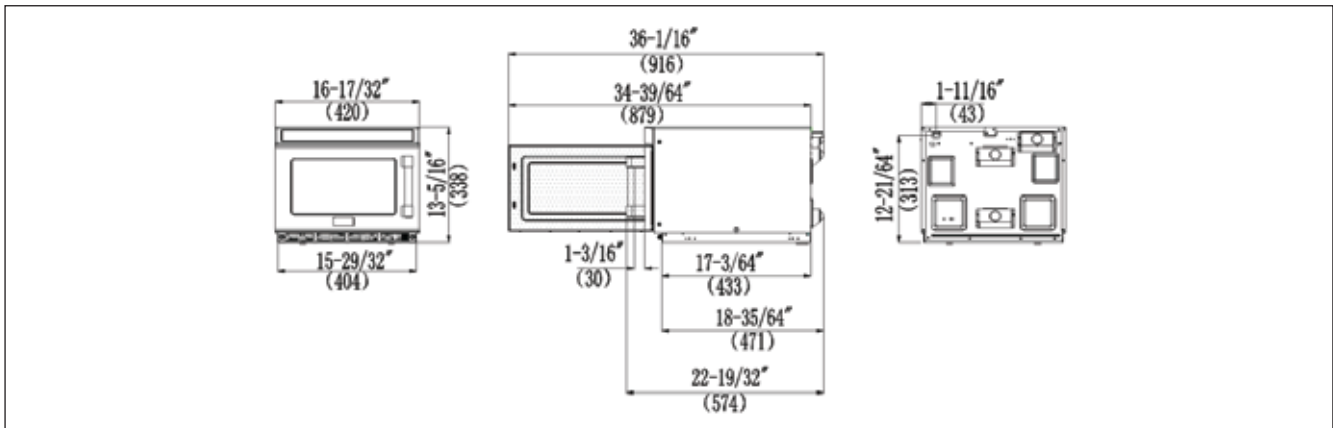

**POWERLINE EQUIPMENT COMPANY**

Pulaski Street, Norwalk, CT 06851 USA. Tel: 203-847 2357 Fax: 203-847 6480

[www.powerlineequip.com](http://www.powerlineequip.com)